

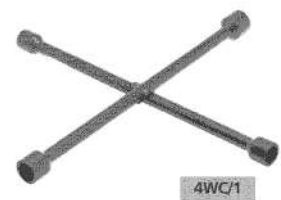

4-Way wheel nut wrenches

Car and commercial sizes

Part No.	Description
4WC/1	To fit most makes of popular cars. 17, 19, 21 and 22mm hexagons. Heat treated carbon steel. Blue epoxy hammer finish. 16mm dia. - 375mm long.
4WC/3	As 4WC/1 with 1/2" square drive in place of 22mm Hex.
4WC/P-CRV Professional Quality.	As 4WC/1 but flange drive hexagons. Made from chrome vanadium, heat treated steel. Satin chrome finish.
4WC/P3-CRV Professional Quality.	To fit most makes of popular cars. 17, 19, 21mm flange drive hexagons and 1/2" square drive. Heat treated vanadium steel. Satin chrome finish. 16mm dia. - 375mm long.
4WL/P 4WL/EL/P	Fit most vans and trucks. 24, 27, 33 and 38mm. Vanadium steel. 22mm dia. Blue epoxy finish. 500mm long 650mm long EL



4WC/1



4WC/CR-V



4WL/P



4WC/3-CR-V



EWB/1

Extending wheel brace

Part No.	Description
EWB/1 Extending Wheel Brace.	Extendable, right angle wheel nut wrench. Suitable for most popular cars. Twin ended sockets, 17x19mm and 21x22mm. 1/2" square drive. Chrome plated with plastic grip. On display card pack.



6-Way wheel nut wrenches (Spider)

Car and commercial sizes

Part No.	Description
6WC/P	To fit most makes of popular cars. 16, 17, 19, 21, 22 and 24mm hexagons. Heat treated carbon steel. Blue epoxy hammer finish. 16mm dia. - 375mm long.
6WC/P3	As above with 1/2" square drive in place of 16mm Hex.



6WC/P



6WC/P3

Commercial sizes

Part No.	Description
6WL/P	To fit most makes of vans and commercial vehicles. 24, 27, 30, 32, 33 and 38mm hexagons. Heat treated vanadium steel. Blue epoxy hammer finish. 22mm dia. - 500mm long.
6WL/EL/P	As above but 650mm long.
6WL/EL/P3	P3 has 3/4" square drive in place of 30mm Hex.



6WL/P



6WL/EL/P3

Wheel nut wrenches



Heavy duty commercial wheel nut wrenches

Heavy duty L - shaped with extension



Hexagon 6 sided			
Part No.	mm	AF (ins)	Whit
HDW/O/E	19	3/4	•
HDW/1/E	28	•	5/8
HDW/2/E	•	1 5/16	3/4
HDW/3/E	30	1 3/16	11/16
HDW/4/E	24	15/16	•
HDW/5/E	27	11/16	•
HDW/6/E *	32	•	•
HDW/7/E *	38	1 1/2	7/8
HDW/8/E	22	7/8	•
HDW/11/E	•	1 1/8	•
HDW/12/E *	33	•	3/4
HDW/E/TB	28 dia. - gives 30" leverage.		

* Available as Re-inforced, order as Part No. above plus /RE

Also available - HDW/2 33mm one piece construction



Bi - hexagon 12 point			
Part No.	mm	AF (ins)	Whit
BHW/2	24	15/16	•
BHW/3 *	27	11/16	•
BHW/4	28	•	5/8
BHW/5 *	30	•	1 3/16
BHW/6 *	32	•	•
BHW/7 *	33	•	3/4
BHW/8	•	1 5/16	•
BHW/9 *	38	11/2	7/8
BHW/10	41	•	•
HDW/E/TB	28 dia. - gives 30" leverage.		

* Available as Re-inforced, order as Part No. above plus /RE

Re-inforced heavy duty L-shape 2 piece.

Starred wrenches are also available as a reinforced extra heavy duty product. Solid forged on 38mm diameter vanadium steel.

Refer to application chart on pages 24/25

Wheel nut wrenches



Square drive wrenches and impact sockets

Heavy duty L - shaped wrench - 1" square drive

Part No.	Description
HDW/10/E	1" Sq. Single ended wrench
HDW/E/TB	• Tommy bar to suit single ended wrench
HDW/10/E/DE	1" Sq. x2 Double ended wrench
HDW/10/E/DE-RE	1" Sq. x2 Re-inforced double ended wrench
HDW/10/E/DE-TB	• Tommy bar to suit double ended wrench
ISA/4	• 1" to 3/4 square drive adaptor

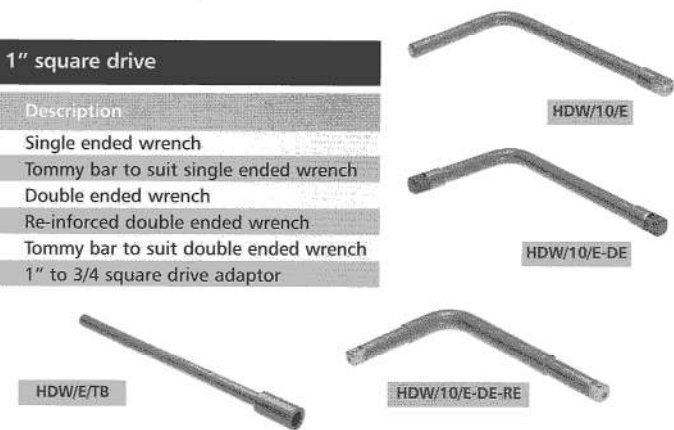

Impact sockets

Size (mm)	3/4" drive standard	3/4" drive deep	1" drive standard	1" drive deep
19	IS1-19	IS2-19	IS3-19	IS4-19
24	IS1-24	IS2-24	IS3-24	IS4-24
27	IS1-27	IS2-27	IS3-27	IS4-27
28	IS1-28	IS2-28	IS3-28	IS4-28
30	IS1-30	IS2-30	IS3-30	IS4-30
32	IS1-32	IS2-32	IS3-32	IS4-32
33	IS1-33	IS2-33	IS3-33	IS4-33
38	IS1-38	IS2-38	IS3-38	IS4-38
41	IS1-41	IS2-41	IS3-41	IS4-41
1 5/16" AF	IS1-1 5/16	IS2-1 5/16	IS3-1 5/16	IS4-1 5/16

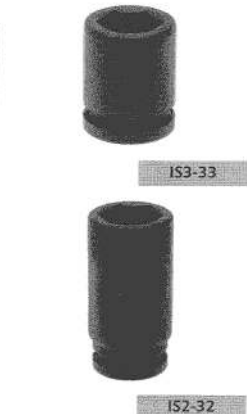

Special purpose sockets

Part No.	Description
NBS/1	17mm - 19mm - 1/2" Drive
NBS/2	24mm - 27mm - 1/2" Drive
Land Rover prop shaft tool PSS-9/16	9/16" AF x 6" Long - 1/2" Drive



Our full warranty does not cover Part No. - NBS/1 - NBS/2 and all adaptors - Due to the nature of the application

Refer to application chart on pages 24/25



Impact sockets



Impact extensions				
Extensions	100mm	150mm	250mm	300mm
1/2" Sq.	IE-1	IE-2	IE-3	•
3/4" Sq.	•	IE-4	IE-5	•
1" Sq.	•	IE-6	IE-7	IE-8

Adaptors				
	Female	Male	Female	Male
ISA-1	3/4	- 1/2	1/2	- 3/4
ISA-2	1	- 3/4	3/4	- 1
			ISA-3	ISA-4

Sets	
Part No.	Description
IS- Set 1	10, 11, 12, 13, 14, 17, 19, 21, 22, 24mm on a rail.
1/2" drive	Standard 10 piece
IS- Set 2	10, 11, 12, 13, 14, 17, 19, 21, 22, 24mm on a rail.
1/2" drive	Deep 10 piece
IS- Set 3	24, 27, 28, 30, 32, 33mm
1" drive	Deep 6 piece
IS- Set 4	24, 27, 28, 30, 32, 33mm
1" drive	Thin wall 5 piece
IS- Set 5	24, 27, 28, 30, 32, 33mm
1" drive	Semi-deep 6 piece



Wheel nut wrenches and winding handles

Wheel brace support stands	
Part No.	Description
WBS/1	To assist the use of all commercial wheel braces giving many different heights of support, allowing the user to give full leverage.

Single end - T-Bar wrench			
Part No.	mm	Part No.	mm
WBT 7	24	WBT 14	1 1/8" AF
WBT 8	1" AF	WBT 16	1 1/4" AF
WBT 9/13	28	WBT 19	27
WBT 10/15	30	WBT 23	23
WBT 11/17	33	WBT 26	26
WBT 12/18	38	WBT 5 TB	600 long

Double ended			
Part No.	Size	Size	Length
DEW-2	28mm	33	450
DEW-4	38mm	1 1/8" AF + 13/16 Sq.	450
DEW-7	33mm	27	450
DEW-12	41mm	21 Sq.	450
DEW/TB		Tommy bar	750

18" long - 450mm

Single ended L-shaped wrench		
Part No.	Size	BAR (mm)
SES-5	19mm	19/14
SES-15/16"	24mm	19/22
SES-1 1/16"	27mm	19/22
SES-22	22mm	22

*Special pattern wrenches available in bulk quantities.

Trailer leg winding handle			
Hex Part No.	Reach (ins)	Clevis Part No.	Reach (ins)
TH-14	14	THC-14	14
TH-18	18	THC-18	18

Caravan brace - for corner steady leg 19mm Hex		
Part No.	Reach (ins)	
CB/1	20	with spinner handle
CB/3	20	without handle



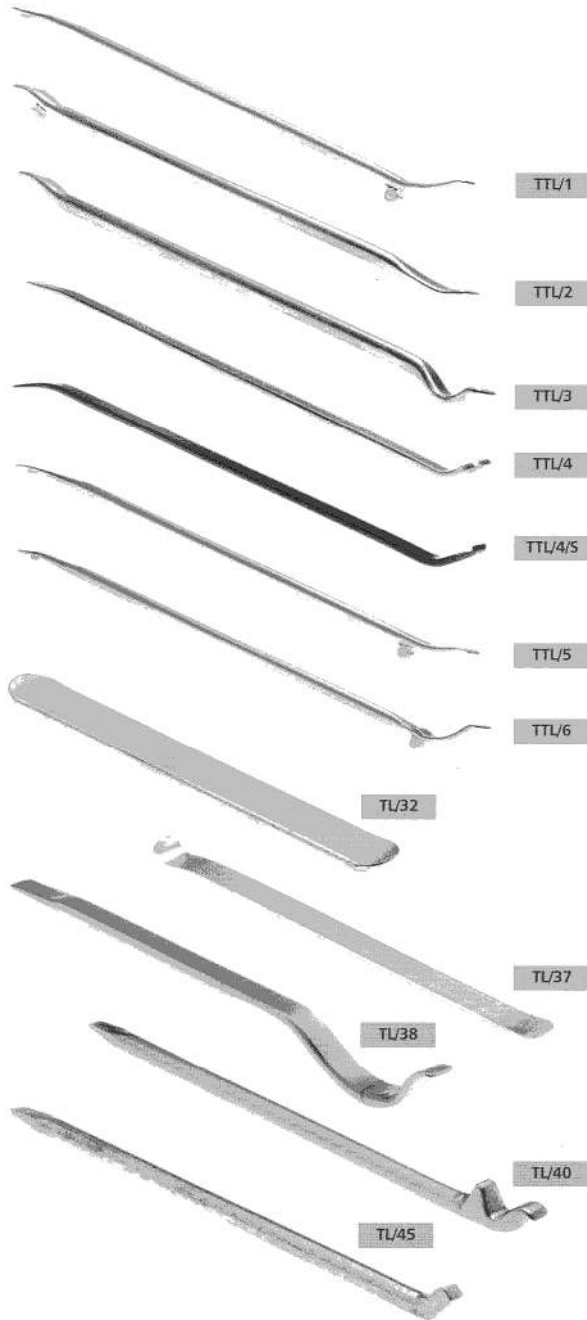

Commercial tubeless tyre levers

Part No.	Description
TTL/1	34"-870mm long 20mm dia.
TTL/2	30"-770mm long 22mm dia.
TTL/3	30"-770mm long 22mm dia.
TTL/4	34"-870mm long 25x12 Bar spring steel
TTL/4/S	30"-770mm long 25x10 Bar spring steel
TTL/5	37 1/2"-970mm long 22mm dia.
TTL/6	39"-990mm long 22mm dia.

Standard tyre levers

Part No.	Description
TL/32	10"-250mm long 1 1/4" wide Flat lever
TL/37	12"-305mm long 18"-450mm long 24"-610mm long 30"-770mm long 36"-900mm long
TL/37	12"-305mm long 7/8" wide Flat lever
TL/38	21"-530mm long 25x12 Flat spring steel
TL/40	19 1/2"-520mm long
TL/45	19"-510mm long

Tyre levers

Part No.	Description
TL/50	23"-600mm long 35x10mm Bar
TL/55	15 1/4"-290mm long 35x10mm Bar
TL/65	7"-180mm long 10mm Ø Bicycle/motorcycle lever
TL/70	12"-305mm long 15mm Ø Bicycle/motorcycle lever
TL/81A	21 1/2"-550mm long 19mm Ø Split rim lever
TL/85	9"-230mm long 25x5mm bicycle/motorcycle lever
TL/88	9"-230mm long 12.5mm Ø
TL/90	12"-305mm long 12.5mm Ø
TL/95	20"-510mm long 15.5mm Ø Spoon lever-universal
TL/100	30"-770mm long 22mm Ø Excavator-split rim lever
TL/105	38 1/2"-980mm long 28mm Ø Earthmover - lever

Tyre changing bars

Part No.	Description
TCB/1	41"-1040mm long Mount-de-mount bar ball and claw
TCB/2	20"-500mm long 24"-600mm long



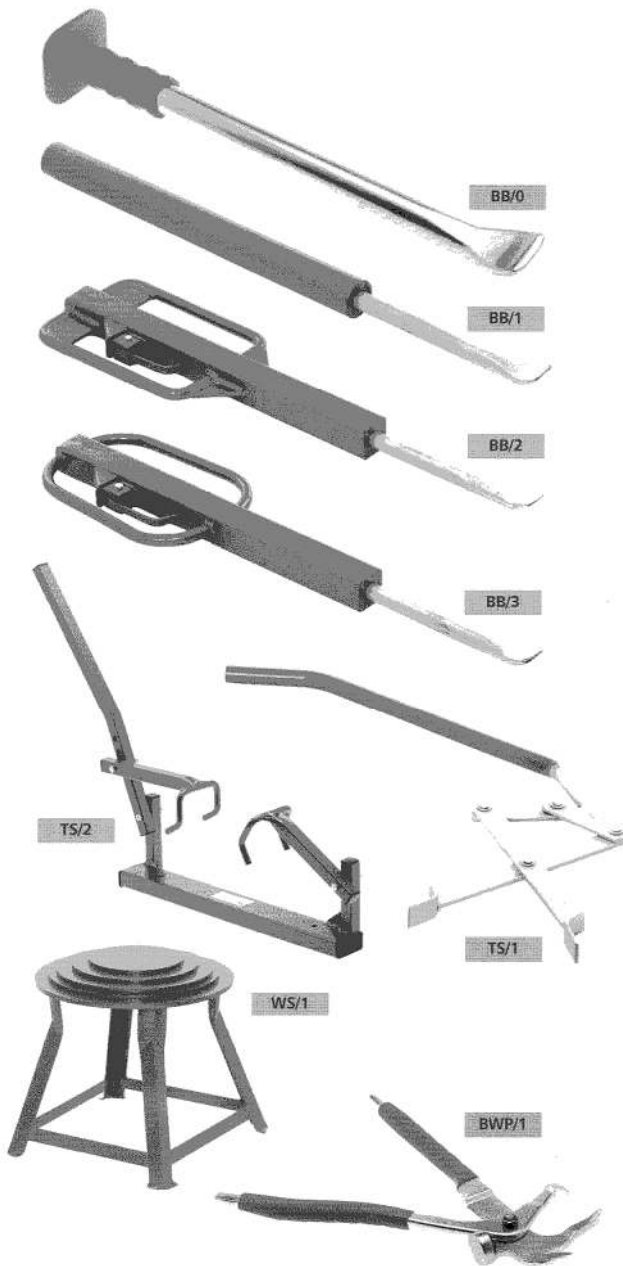

Manual bead breakers

Part No.	Description
BB/0	20"-500mm long (Bead chisel with protective handle)
BB/0S	10"-250mm long (Bead chisel with protective handle)
BB/1	Single pole sliding hammer style 37"-960mm closed 61"-1550mm open
BB/2	Heavy duty Double handle 38"-980mm closed 62"-1570mm open
BB/3	Budget Double handle 37"-960mm closed 61"-1550mm open

Tyre spreaders

Part No.	Description
TS/1	Single handed tyre inspection car and van tyres
TS/2	Bench type Car and van tyres

Tyre stools

Part No.	Description
WS/1	Heavy duty tyre fitters stool for multiple uses

Balance weight pliers

Part No.	Description
BWP/1	Top quality chrome vanadium balance weight pliers Smooth function

Axle stands

Part No.	Capacity SWL-KG each/pair	Min height	Max height	Crutch width
AS/5	1500/3000	250mm	400mm	54-84mm
AS/10	2000/4000	300mm	500mm	54-84mm
AS/10BS	2000/4000	300mm	500mm	54-84mm
AS/20	3000/6000	300mm	500mm	88mm V
AS/20A	3000/6000	300mm	500mm	88-95mm
AS/30	4000/8000	500mm	750mm	88mm V
AS/30A	4000/8000	500mm	750mm	88-95mm
AS/40S	6000/12000	300mm	500mm	144mm
AS/40	6000/12000	540mm	1000mm	144mm
AS/40HD	8000/16000	540mm	1000mm	144mm
AS/45	12000/24000	300mm	500mm	144mm
AS/45/HD	16000/32000	300mm	500mm	144mm
AS/50	6000/12000	700mm	1250mm	144mm
AS/60	6000/12000	1450mm	1750mm	144mm

Feet AS/40 to AS/60 available with disc's on as feet - for added stability. At extra cost

Wheels The larger stands, AS/50 - AS/60 are available with wheels to make moving round the workshop easier

Pins & chains Spare pins and chains are available for all stands

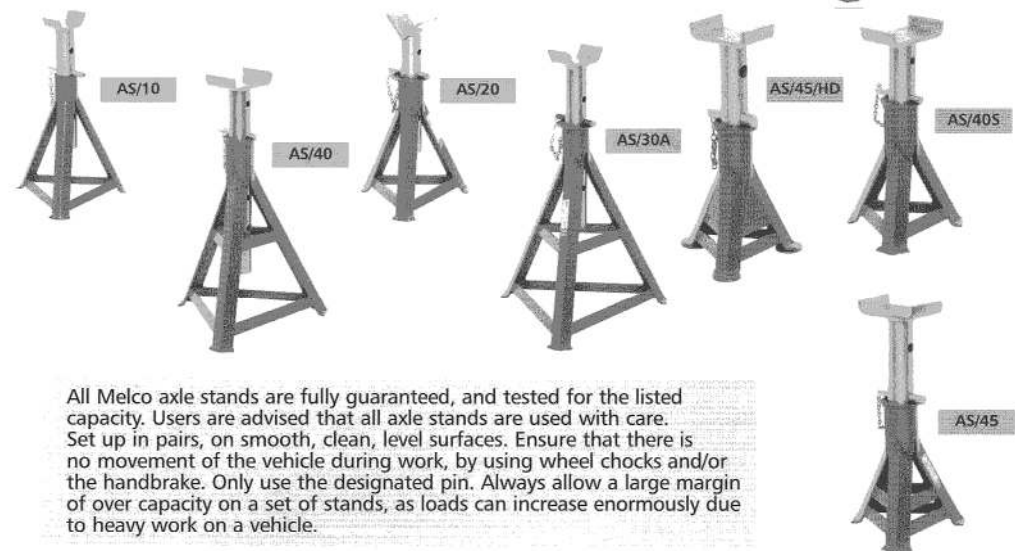

All Melco axle stands are fully guaranteed, and tested for the listed capacity. Users are advised that all axle stands are used with care. Set up in pairs, on smooth, clean, level surfaces. Ensure that there is no movement of the vehicle during work, by using wheel chocks and/or the handbrake. Only use the designated pin. Always allow a large margin of over capacity on a set of stands, as loads can increase enormously due to heavy work on a vehicle.

Car ramps

Part No.	Platform max height	Platform width-height	Total length	Capacity each/pair
CR/2	243mm	180-300mm	1000mm	1500/3000Kg
CR/3	250mm	220-340mm	1300mm	1000/2000Kg
CR/4	230mm	230-300mm	940mm	1000/2000Kg

The longer - gentle angle of the CR/3 allows lowfronted cars to glide up to working height

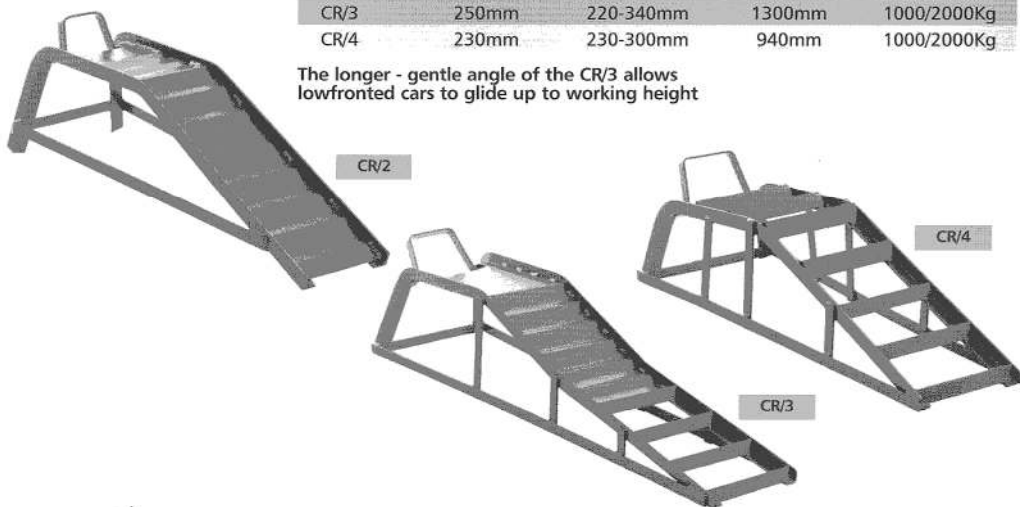

WC/1

Wheel chocks

Part No.	Description
WC/1	Light - robust wheel chocks for keeping small to medium vehicles, trailers, caravans etc. in place while needed ie. on car ramps, axle stands, while loading



MCGA

Ground anchors

Part No.	Description
MCGA	Cement fixing
MCGA/3	Bolt fixing complete with bolt stand fixtures

When set in, or fixed to a solid base (concrete or masonry) these form a secure, solid, anchor point to chain your vehicle, boat, trailer, motorcycle or plant, to deter theft.



MCGA/3

Spark plug spanners

Standard plug spanner - single ended

Part No.	Plug size	AF
PS/25	14mm	21mm

Loop handle plug spanner

Part No.	Plug size	AF
PS/15	10mm	16mm
PS/12	12mm	18mm
PS/21	14mm	21mm
PS/14	14mm	21mm
PS/29	10x12mm	16x18mm

Long reach plug spanner

Part No.	Plug size	AF	Length
PS/28/EL	10mm	16mm	300mm
PS/25/EL	14mm	21mm	300mm
PS/27/EL	12mm	18mm	300mm
PS/29/B	12mm	18mm	175mm
PSF/1	5/8"AF	15.5mm	175mm

T Handle plug spanner

Part No.	Plug size	AF	Length
PS/38	10mm	16mm	225mm
PS/35/S	14mm	21mm	225mm
PS/35/A	14mm	21mm	300mm



PS-25

PS-21

PS-28/EL

PS-25/EL

PS-38

Tubular spark plug spanners are designed so that you DO NOT OVER TIGHTEN the spark plugs - which can lead to damage - always refer to manufacturers instructions.

Point of sale packaging.
Please refer to page 20/21

Hub nut spanners

Hexagons-6-sided (Incorporating 3/4" Square Drive)

Part No.	mm	Imperial	Application
TBS 98	30	1 - 3/16"	VAUXHALL/RENAULT/G. M.C HUBS
TBS 67	38	1 - 1/2"	MINI CLUTCH
TBS 99	41	1 - 9/32"	FORD SIERRA
TBS 53	42	1 - 21/32"	COMMER TS/3
TBS 82	44	1 - 3/4"	LEYLAND BALLJOINTS
TBS 95	46	1 - 13/16"	FORD-D-SERIES/FORD CARGO
TBS 54	48	1 - 7/8"	WOLSEY 1500 + OTHER BMC CARS
TBS 68	51	2"	
TBS 89	52	2 - 1/16"	LAND ROVER
TBS 86	54	2 - 1/8"	
TBS 97	55	2 - 3/16"	R.O.R. L.M. AXLE
TBS 81	57	2 - 1/4"	FORD BUS (FRONT)
TBS 57	62	2 - 27/64"	COMMER Q25
TBS 69	64	2 - 1/2"	VOLVO
TBS 92	64.5	2 - 17/32"	TRANSIT
TBS 65	67	2 - 41/64"	TRANSIT (EARLY MODELS)
TBS 58	70	2 - 3/4"	BEDFORD 2 TONNE
TBS 59	71	2 - 13/16"	COMMERTS3 (REAR)
TBS 76	74	2 - 7/8"	
TBS 60	77	3"	BEDFORD 3 TONNE
TBS 88	80	3 - 1/8"	LEYLAND ROADRUNNER .IVECO
TBS 61	81	3 - 5/32"	COMMER Q4 SEDDON ATKINSON
TBS 78	83	3 - 1/4"	SEDDON ATKINSON
TBS 63	86	3 - 3/8"	EATON 16500 AXLE
TBS 62	90	3 - 1/2"	FORD BUS(REAR) FORD-D-SERIES HYSTER
TBS 102	92	3 - 5/8"	
TBS 100	95	3 - 3/4"	SAF/RENAULT/IVECO
TBS 90	97.5	3 - 13/16"	
TBS 70A	99	3 - 7/8"	EATON SINGLE-TWO SPEED
TBS 66	102	4"	EATON 18500 FORD CARGO.FODEN
TBS 87	105	4 - 1/8"	SCANIA.DAF 2500
TBS 84	106	4 - 3/16"	GUY J6.VOLVOFL4
TBS 106	108	4 - 1/4"	
TBS 77	113	4 - 3/8"	SEDDON ATKINSON(REAR HUB)IVECO
TBS 64	115	4 - 1/2"	LEYLAND BUS.FODEN D+F.G(REAR HUB)
TBS 107	120	4 - 3/4"	
TBS 93	123	4 - 7/8"	DAF REAR HUB



TBS 86

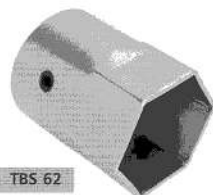

TBS 62

new stronger
3/4" drive



TBS 106

Octagon-8-sided

Part No.	mm	Imperial	Application
TBS 45	45.5		
TBS 55	50	1 - 61/64"	OXFORD/AUSTIN A55 M.G.A.-M.G.B
TBS 56	56	2 - 13/64"	J2 VAN TAXI CAB
TBS 94	61	2 - 3/8"	FORD-D-SERIES CARGO
TBS 74	77	3"	
TBS 108	80	3 - 1/8"	
TBS 79	83	3 - 1/4"	R.O.R.TM SERIES
TBS 80	86	3 - 3/8"	EATON 16500 AXLE
TBS 75	95	3 - 3/4"	R.O.R.TM SERIES
TBS 85	102	4"	VOLVO/SCANIA
TBS 104	108	4 - 1/4"	PRO PAIR ALLOY DUST COVER(FRUEHAUF)
TBS 105		4 - 3/8"	
TBS 96	115	4 - 1/2"	VOLVO FL10
TBS 83	117	4 - 5/8"	R.O.R. ROCKWELL
TBS 101	122	4 - 13/16"	
TBS 91	83 x 95	3 - 1/4" x 3 - 3/4"	CRANE FRUEHAUF
T.47	5/8" DIA.	12" LONG	TOMMY BAR TO SUIT ALL ABOVE

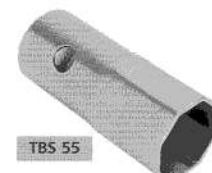

TBS 55



TBS 94

Dispenser

A point of sale dispenser is available to hold a range of hub nut spanners.

Also available

3/4" drive sliding T bar

Diesel injector spanners

Part No.	Description
DIS/27	27mm 10"-250mm long
DIS/30	30mm 10"-250mm long
DIS/32	32mm 10"-250mm long

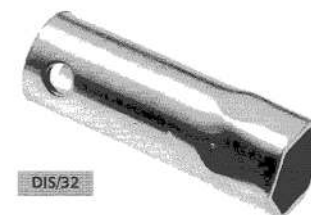

DIS/32

Tubular box spanners



Metric - double ended

Part No.	Size across flats (mm)	Length (ins - mm)	Across Hexagon flats (ins)	T Bar (mm)
TM.1	6 x 7	4 - 100	.238 x .278	4.8
TM.4	8 x 9	4 - 100	.319 x .358	4.8
TM.6	10 x 11	4 - 100	.398 x .437	6.35
TM.7	10 x 11	7 - 175	.398 x .437	6.35
TM.8	12 x 13	3 1/4 - 82	.476 x .516	6.35
TM.9	12 x 13	4 - 100	.476 x .516	6.35
TM.10	12 x 13	7 - 175	.476 x .516	6.35
TM.11	12 x 14	4 - 100	.476 x .555	6.35
TTS/33	13 x 13	7 - 125	.516 x .526	6.35
TM.13	14 x 15	3 1/4 - 82	.555 x .595	6.35
TM.14	16 x 17	5 - 125	.634 x .673	6.35
TM.16	17 x 19	5 - 125	.673 x .752	8
TM.17	18 x 19	5 - 125	.713 x .752	9.5
TM.19	20 x 21	5 - 125	.793 x .833	9.5
TM.20	20 x 22	5 - 125	.793 x .872	9.5
TM.21	21 x 22	3 1/4 - 82	.833 x .872	9.5
TM.22	22 x 23	5 - 125	.872 x .912	9.5
TTS/40	24 x 24	7 - 175	.955 x .955	12.7
TM.24	24 x 25	6 - 150	.953 x .992	12.7
TM.25	24 x 26	5 - 125	.953 x 1.023	12.7
TM.26	27 x 32	6 - 150	.953 x 1.023	12.7



ISO metric

Part No.	Size across flats ISO-metric (mm)	Length (ins - mm)	Across Hexagon flats (ins)	Nominal bolt size	T bar (mm)
TIM.1	3.2 x 4	4 - 100	.126 x .157	M1.6 x M2	4.8
TIM.2	5 x 5.5	4 - 100	.196 x .127	M2.5 x M3	4.8
TIM.3	7 x 8	4 - 100	.278 x .319	M4 x M5	6.35
TIM.4	8 x 10	4 - 100	.319 x .398	M5 x M6	6.35
TIM.5	13 x 17	5 - 125	.516 x .673	M8 x M10	6.35
TIM.6	19 x 22	5 - 125	.752 x .872	M12 x M14	8
TIM.7	24 x 27	6 - 150	.953 x 1.062	M16 x M18	9
TIM.8	30 x 32	6 - 150	1.181 x 1.259	M20 x M22	9
TIM.9	36 x 41	7 - 175	1.417 x 1.614	M24 x M27	12.7
TIM.10	46 x 50	7 - 175	1.811 x 1.968	M30 x M33	15.5
TIM.11	55 x 60	8 - 200	2.165 x 2.362	M36 x M39	15.5
TIM.12	65 x 70	8 - 200	2.559 x 2.755	M42 x M45	15.5
TIM.13	75 x 80	8 - 200	2.953 x 3.149	M48 x M52	15.5

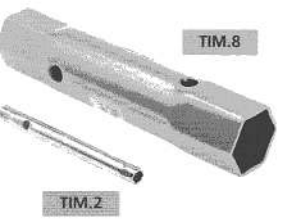

Tubular box spanners



Metric single ended

Part No.	Size (mm)	Length ins - mm	Across Hexagon flats (ins)	T bar (mm)
SME.5	10	2 - 50	.398	6.35
SME.6	11	2 - 50	.437	6.35
SME.8	13	3 - 75	.516	6.35

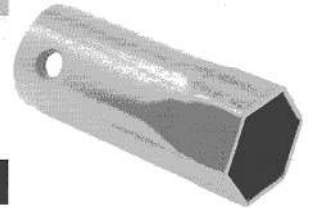

BA double & single ended

Part No.	Size BA	Length (ins - mm)	Across Hexagon flats (ins)	T bar (mm)
TBA.1	0 x 1	3 - 75	.413 x .365	6.35
TBA.3	0 x 2	3 - 75	.415 x .324	6.35
TBA.4	2 x 3	3 - 75	.324 x .282	4.8
TBA.7	4 x 5	3 - 75	.248 x .220	4.8
TBA.9	4 x 6	3 - 75	.248 x .193	4.8
TBA.10	6 x 7	3 - 75	.193 x .172	3.2
TBA.13	8 x 9	3 - 75	.152 x .131	3.2
SBA.20	10 BA	3 - 75	.117	3.2



AF double ended box spanners

Spanner sizes are the same as the width of the nut measured in inches across the hexagon flats.

Bright plated finish or silver epoxy.

Part No.	Size ins	Length ins - mm	Across Hexagon flats (ins)	Hole size (mm)
TA.0	1/4 x 5/16	4 - 100	0.250 x 0.312	4.8
TA.1	5/16 x 3/8	4 - 100	0.312 x 0.375	6.35
TA.2	3/8 x 7/16	4 - 100	0.375 x 0.437	6.35
TA.4	7/16 x 1/2	4 - 100	0.437 x 0.500	8
TA.6	1/2 x 9/16	4 - 100	0.500 x 0.562	8
TA.8	9/16 x 5/8	5 - 125	0.562 x 0.625	8
TA.11	5/8 x 3/4	5 - 125	0.625 x 0.750	9.5
TA.12	11/16 x 3/4	6 - 150	0.687 x 0.750	9.5
TA.14	3/4 x 7/8	5 - 125	0.750 x 0.875	9.5
TA.16	13/16 x 7/8	5 - 125	0.812 x 0.875	9.5
TA.17	7/8 x 15/16	5 - 125	0.875 x 0.937	9.5
TA.18	7/8 x 1	6 - 150	0.875 x 1.000	9.5
TA.20	15/16 x 1	7 - 175	0.937 x 1.000	9.5
TA.21	1 x 1-1/8	7 - 175	1.000 x 1.125	9.5
TA.22	15/16 x 1-1/8	6 - 150	0.937 x 1.125	9.5
TA.23	1-1/4 x 1-7/16	7-1/2 - 190	1.250 x 1.437	12.7
TA.24	1-5/16 x 1-1/2	7-1/2 - 190	1.312 x 1.500	12.7
TA.25	1-5/8 x 1-13/16	7-1/2 - 190	1.625 x 1.812	12.7

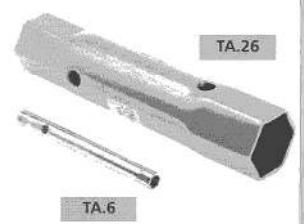

Tubular box spanners



Double ended box spanners (Whitworth)

Spanner sizes are determined by the size of the thread on the bolt or stud. Sizes given are BS 2558 Grade B.

Bright plated finish or silver epoxy.

Part No.	Size ins	Length ins - mm	Across Hexagon flats (ins)	Hole size (mm)
TW.2	1/8 x 3/16	4 - 100	0.338 x 0.445	6.35
TW.4	3/16 x 1/4	4 - 100	0.445 x 0.525	8
TW.7	1/4 x 5/16	4 - 125	0.525 x 0.600	8
TW.10	5/16 x 3/8	5 - 125	0.600 x 0.710	8
TW.13	3/8 x 7/16	5 - 125	0.710 x 0.820	9.5
TW.14	7/16 x 1/2	5 - 125	0.820 x 0.920	9.5
TW.16	1/2 x 9/16	6 - 150	0.920 x 1.010	9.5
TW.18	9/16 x 5/8	6 - 150	1.010 x 1.100	9.5
TW.20	5/8 x 11/16	6 - 150	1.100 x 1.200	9.5
TW.21	5/8 x 3/4	7 - 175	1.100 x 1.300	9.5
TW.23	3/4 x 7/8	7 - 175	1.300 x 1.480	9.5
TW.24	7/8 x 1	7 - 175	1.480 x 1.670	12.7
TW.25	1 x 1-1/8	7 - 175	1.670 x 1.860	12.7
TW.27	1-1/4 x 1-1/2	7 - 175	2.050 x 2.410	12.7
TW.28	1-3/8 x 1-1/2	8-1/2 - 215	2.220 x 2.410	12.7

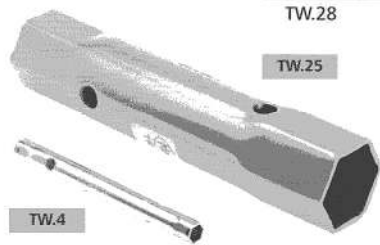

TW.25

TW.4

Single ended box spanner (Whitworth)

Part No.	Size (mm)	Length ins - mm	Across Hexagon flats (ins)	T bar (mm)
SW.12	1-1/4 Whit x 52	6 - 150	2.05	12.7



TW.25

Tubular box spanners



Tubular box spanner sets

Metric

Part No.	Description
Set-1M	6 - 19mm + Bars
Set-2M	12 - 27mm + Bars

AF

Part No.	Description
Set-3AF	3/8" - 1 1/8" AF + Bars

Whitworth

Part No.	Description
Set-4W	1/8" - 1" Whit + Bars

BA

Part No.	Description
Set-53B	0 - 10 BA + Bars



Tommy bars

Part No.	Diameter (ins - mm)	Length (ins - mm)	Type
T.30	1/8 - 3.2	2-3/8 - 60	Parallel
T.31	3/16 - 4.8	3 - 75	Parallel
T.32	1/4 - 6.35	3 - 75	Parallel
T.33	1/4 - 6.35	4 - 100	Parallel
T.34	1/4 - 6.35	6 - 150	Parallel
T.35	5/16 - 8	4 3/4 - 120	Parallel
T.36	5/16 - 8	6 - 150	Parallel
T.38	3/8 - 9	6 - 150	Parallel
T.39	3/8 - 9	8 - 200	Parallel
T.42	5/16 to 3/8 - 8 to 9	6 - 150	Stepped
T.44	1/2 - 12.7	7-1/2 - 175	Parallel
T.47	5/8 - 15.5	12 - 300	Parallel



T.34

T.42

T.44

Special order box spanners

Tubular box spanners are available to your own specification subject to quantity and acceptance.

Cards

The figures in brackets denotes the number of items on each card.

Card No.	Contents	Card No.	Contents
4	PS/14 14mm plug spanners (12)	27A	FG/2 Metric feeler gauges (12) (12)
7	TL/85 Motorcycle tyre levers (12)	28	PS/12 12mm plug spanners (12)
8	CH/1 6" Cold chisels (6)	32	PS/29 10 x 12mm plug spanners (12)
9	TL/65 Motorcycle tyre levers (12)	32A	PS/29B 12mm long reach motorcycle plug spanners (12)
14	PS/33 Motorcycle plug spanners (12)	33	PS/21 14mm plug spanners (6)
23	LP/1 Line pins (12)	34	VG/1&2 Valve grinders (12)
27	FG/1 Imperial feeler gauges (12)	37	PS/15 10mm plug spanners (12)



Hanging card

Completely new design hanging cards complete with product application and bar coding and once again our most popular sellers are illustrated with the full range depicted below.

Part No.	Description
PS/15/C	10mm plug spanner
PS/21/C	14mm plug spanner
PS/29/C	10 x 12mm M/C plug spanner
PS/38/C	10mm long reach plug spanner T handle
PS/35/C	14mm long reach plug spanner T handle
PSF/1/C	10mm (5/8" AF) for Ford Escort 1981 onwards
PS28/EL/C	10mm long reach plug spanner with captive T. Bar (12" long)
PS25/EL/C	14mm long reach plug spanner with captive T. Bar (12" long)
VG/1/C	3/4" & 7/8 dia. Valve grinder (Also available VG/2/C 7/8" x 1 1/4" dia.)



THOMAS MELDRUM LIMITED,
SHEFFIELD, ENGLAND.

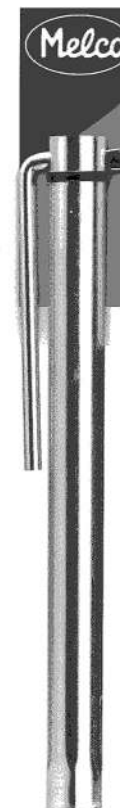

THOMAS MELDRUM LIMITED,
SHEFFIELD, ENGLAND.

Hardware, construction & engineering tools

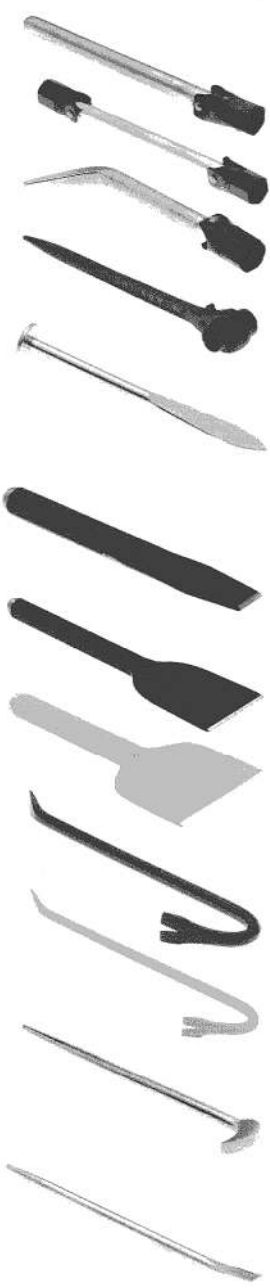

Scaffolding spanners

Part No.	Size (ins)	Length (ins - mm)
TSS/1 *	7/16" Whit (21mm)	9 - 228
TSS/2	1/2" Whit	9 - 228
TSS/3	7/16" x 1/2" Whit	9 - 228
TSS/4 *	7/16" Whit with Podger Bar	9 - 228
TSS/5	1/2" Whit with Podger Bar	9 - 228
22mm AF	22mm	9 - 228
RPS/1	19 x 21 Reversible ratchet spanner	12 - 300

* 22mm AF - available to order

Bricklayers line pins

Part No.	Description
LP/1	Overall Length 7" (Available on Display Card No. 23)

Cold chisels

Part No.	Description
CH/1	Manufactured from high carbon steel fully heat treated 6" x 1/2". (Available on Display Card No. 8)
CH/2	8" x 3/4"
CH/3	12" x 1"

Electricians bolster chisel

Part No.	Description
CH/EB	9" x 2 1/4" wide

Brick bolster

Part No.	Description
CH/BB	9" x 3 1/2" wide

Chisels available with hand guards

Wrecking bars

Part No.	Description	Part No.	Description
WKB/18	5/8" dia x 18"	WKB/24	3/4" dia x 24"
WKB/18	3/4" dia x 30"	WKB/36	1" dia x 36"

Chisels and wrecking bars are available in black or hi-vis yellow

Heel bar range

Part No.	Description	Part No.	Description
HB/7	Length 7"(180mm)	HB/12	Length 12"(305mm)
HB/16	Length 16"(410mm)	HB/18	Length 18"(450mm)

Pry bar lever range

Part No.	Description	Part No.	Description
PBL/18	Length 18"(450mm)	PBL/24	Length 24"(610mm)
PBL/30	Length 30"(777mm)		

Wheel Nut Sizes Application Chart. Cars.

Make	17mm	19mm	21mm	22mm	Recommended Torque NM./FTLB
ALFA ROMEO	-	•	-	-	95/70
AUDI	•	-	-	-	110/81
BMW	•	-	-	-	110/81
CHRYSLER	•EU	•US	•FEW	-	130/96
CITROEN	-	•	-	-	80/59
DAEWOO	-	•	-	-	N/A
DAIHATSU	•	-	•	-	100/74
DAIMLER GB	-	•	-	-	68/50
FIAT	-	•	-	-	70-85/60-63
FORD	••24mm Transit Twin	-	-	-	70-100/60-74
GEN MOTORS	•	•	•	-	N/A
HONDA	-	•	-	-	110/81
ISUZU	-	•	-	-	90-120/66-88
JAGUAR	-	•	-	•	68-70/50-52
KIA	-	•	•	-	N/A
LADA	-	•	-	-	70/52
LANCIA	-	•	-	-	90/66
MASERATI	-	•	-	-	80-100/59-74
MAZDA	-	•	•	-	90-110/66-81
MITSUBISHI	-	-	•	-	90-100/65-81
MERCEDES	•	•Vans (185/137)	-	-	100-150/74-111
NISSAN	-	-	•	-	80-118/59-87
OPEL/VAUXHALL	•	-	-	-	90/66
PEUGEOT	-	•	-	-	60-90/44-66
PROTON	-	•	-	-	N/A
PORCHE	•	-	-	-	130/96
RENAULT	-	•	-	-	60-100/44-74
ROLLS ROYCE	-	-	•	-	65/48
ROVER MG	•Mini	•Rest	-	-	57-110/42-81
SAAB	-	•	-	-	105-125/77-92
SEAT	•	-	-	-	87/64
SKODA	-	•	-	-	60-90/44-66
SUBARU	-	•	-	-	80-100/59-74
SUZUKI	•All	•Escudo	-	-	50-80/37-59
TOYOTA	-	-	•	-	103-160/76-118
VOLKSWAGEN	•	•Vans (160/118)	-	-	110/81
VOLVO	•440-80	•Most	•S40 V40	-	80-120/59-89

These figures are for reference only. Always refer to manufacturers manual for correct figures regarding particular models. All our wheel braces are designed to meet these requirements. Any over tightening of nuts or the use of extra extensions etc to gain extra leverage voids any warranty.

Wheel Nut Sizes - Application Chart. Commercial Vehicles.

Size (mm)	24	27	28	30	32	33	36	38	41 (1 1/8')
BEDFORD	-	-	•3T	•2T	-	-	-	-	-
BPW	-	•	-	•	-	-	-	-	-
CASE	-	-	-	•	-	-	-	-	-
CAT	-	-	-	-	-	-	-	•	-
DAF	-	•	-	-	-	-	-	-	-
DISC LOCK	-	-	-	-	-	•	•	-	-
ERF	-	•	•	•	-	-	-	-	-
FIAT	-	•	-	-	-	-	-	-	-
FORD	•	•	-	-	-	-	-	-	-
FRUHAUF	-	-	-	•	-	-	-	-	-
HINO	-	-	-	-	-	-	•	-	-
HUNTON	-	-	-	-	•	-	-	-	-
IVECO	•	•	-	-	-	-	-	-	-
JCB	-	-	-	-	-	-	-	•	-

Size (mm)	24	27	28	30	32	33	36	38	41 (1 1/8')
LEYLAND	-	-	•	-	-	•	-	-	-
L ROVER	-	•	-	-	-	-	-	-	-
MAG D	-	•	-	-	-	-	-	-	-
MAN	-	-	-	-	-	-	-	-	-
MERC	•7.5	-	-	•	-	-	-	-	-
OLD LR	•	-	-	-	-	-	-	-	-
RENAULT	-	•	-	-	-	-	-	-	-
RO	-	-	-	-	•	•	-	•	-
SAF	-	-	-	-	-	•	-	-	-
SCAMMEL	-	-	-	•	-	•	-	-	-
SCANIA	-	-	-	-	-	•	-	-	-
TWIN LOCK	-	-	-	-	-	-	-	•	-
VOLVO	-	•	-	-	•	•	-	-	-
V.W.	-	•	-	-	-	-	-	-	-